

CACTUS OPEN SOURCE CODE FOR HYDROKINETIC TURBINE DESIGN AND ANALYSIS: MODEL PERFORMANCE EVALUATION AND PUBLIC DISSEMINATION AS OPEN SOURCE DESIGN TOOL

Carlos Michelen¹
Sandia National Laboratories
Albuquerque, New Mexico, USA

Jonathan C. Murray
Sandia National Laboratories
Albuquerque, New Mexico, USA

Vincent S. Neary
Sandia National Laboratories
Albuquerque, New Mexico, USA

Mathew Barone
Sandia National Laboratories
Albuquerque, New Mexico, USA

¹Corresponding author: cmichel@Sandia.gov

ABSTRACT

Sandia National Laboratories recently released an open source code for design and analysis of axial-flow and cross-flow marine and hydrokinetic (MHK) turbines, CACTUS (Code for Axial and Cross-flow Turbine Simulation), and has initiated an outreach effort to promote its use among MHK researchers and developers. Our aim in this paper is to summarize the recent developments in CACTUS, and present model performance evaluation results that demonstrate CACTUS's potential use as a design and optimization tool for marine hydrokinetic turbines. We present several model validation tests to evaluate the model's ability to predict MHK turbine performance. The results show both the potential use of CACTUS as a design tool and its current limitations. At least two more model validation tests are planned for 2014 as part of this effort: scaled model tests of DOE's Reference Model 1 (RM1) and Reference Model 2 (RM2) turbines in 2014 at the University of Minnesota's St. Anthony Falls Laboratory (SAFL).

INTRODUCTION

Mid- and high-fidelity numerical models can be useful tools in the design and analysis of marine and hydrokinetic (MHK) turbines. Mid-fidelity tools are specifically useful in early design since they allow for quick analysis of a large number of designs and inflow conditions. CACTUS is a hydrokinetic turbine performance code, based on a free vortex method, under development at Sandia National Laboratories (SNL)[1].

Similar numerical tools have been in use for decades in the wind energy field and have been

validated extensively. Because of the inherent differences between the air and water environments, and the different scales and flow conditions, it is necessary to validate these tools for MHK turbines. Measurements for the validation tests were derived from scaled model experiments of DOE's Reference Models and the Sandia turbine [2]. Three model validation tests with CACTUS were performed, including scaled models of axial and cross flow turbines, where CACTUS simulation results were compared to experimental data. These tests include a scaled model of a modified Reference Model 2 (RM2) turbine tested at the University of New Hampshire, a scaled model of the Reference Model 1 (RM1) turbine tested at the United States Naval Academy, and a scaled model of the Sandia turbine tested at Pennsylvania State University's Applied Research Laboratory. At least two more model validation tests are planned as part of this effort: scaled model tests of DOE's Reference Model 1 (RM1) and Reference Model 2 (RM2) turbines in 2014 at the University of Minnesota's St. Anthony Falls Laboratory (SAFL).

SANDIA TURBINE

The Sandia turbine (Figure 1) is a 3-bladed constant pitch axial flow turbine with a rotor diameter of 5m designed for optimal hydrodynamic performance. It was designed to optimize power performance at the design condition, reduce likelihood of cavitation, reduce effect of soiling/bio-fouling on power performance, reduce singing (noise pollution) and reduce fatigue. It uses the MHKF1 family of three

hydrofoils[3]. A 1:8.7 scale model was tested at the Applied Research Laboratory (ARL)[4]. This test was simulated with CACTUS to allow comparison of performance curves with those measured. The CACTUS geometry is shown in Figure 2. The geometry was created using the MATLAB geometry creation scripts included within CACTUS. Lift and drag coefficients for the foil for a range of angle of attack up to stall were predicted using Xfoil (a popular code for 2D airfoil analysis). The results were then extrapolated using the Viterna method[5]. This was done for each of the three foils and for nine different Reynolds numbers.

The rotor performance results of the CACTUS simulation are compared to the experimental data from ARL in Figure 3. The measurements shown were collected for the test case with an inflow velocity of 5 m/s. The plot shows that the CACTUS predictions agree well with the ARL measurements for all tip speed ratios (TSR).

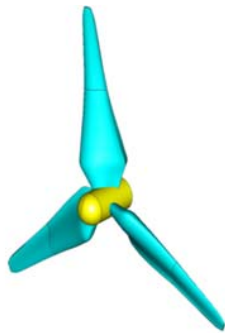

FIGURE 1. CAD DRAWING OF THE SANDIA TURBINE.

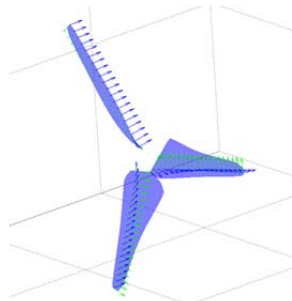

FIGURE 2. CACTUS GEOMETRY OF SANDIA TURBINE.

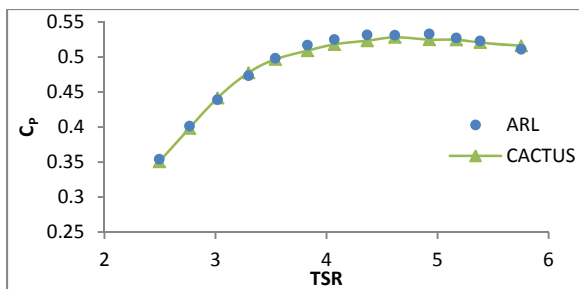

FIGURE 3. COMPARISON OF POWER COEFFICIENT BETWEEN ARL EXPERIMENT AND CACTUS SIMULATION.

UNH EXPERIMENT

A three bladed, vertical axis, cross flow turbine with straight, constant chord blades was tested at the University of New Hampshire (UNH)[6]. The turbine geometry and dimensions are shown in Figure 4. The design was meant to be a simple version of DOE's RM2 turbine. The CACTUS model geometry is shown in Figure 5.

CACTUS predictions are compared to measurements in Figure 6. Large discrepancies are observed, indicating poor model performance. Instability in the free wake evolution, due to local regions of upstream flow, was observed when plotting wake trajectories and is likely caused by the high chord-to-radius ratio. The scaled model turbine used in this experiment has a higher chord-to-radius ratio ($c/R=0.28$) than that anticipated for an MHK turbine. The actual RM2 turbine has a much lower chord-to-radius ratio ($\max c/R=0.124$) and a CACTUS simulation shows no wake instability issues. Hence, better agreement is anticipated.

Attempts to overcome the chord-to-radius limitation involved altering the wake evolution by using more time steps per revolution and manually increasing the wake vortex core radius. The results of one such case, using three times more iterations per revolution and a factor of 2.5 on the wake vortex core radius, is shown in Figure 6 (CACTUS Modified). These techniques resulted in improved wake behavior and suggest that the chord to radius limitation could be overcome (or at least the wake stability issues) with better wake evolution methods. One potential problem of this approach would be the increase in computational time due to higher wake resolution. This could be addressed by decoupling the near and far wake models, allowing more time steps without significantly increasing the number of far wake elements (free vortex elements). If this does not completely resolve this problem, more direct modeling of the viscous effects in the wake should be considered. In the meantime, the wake for any simulation with a high chord-to-radius ratio ($c/R > \sim 0.25$) must be checked for instabilities.

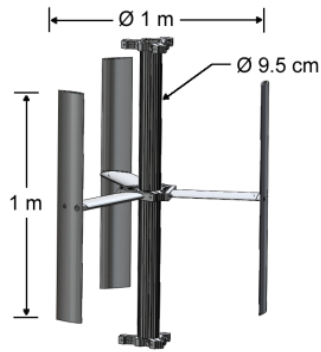

FIGURE 4. DIMENSIONS OF TURBINE TESTED AT UNH.

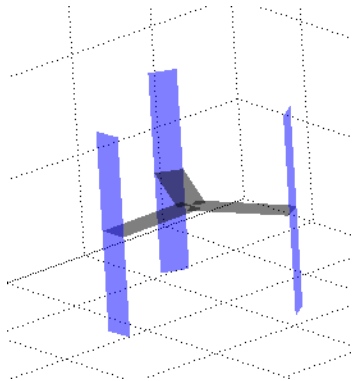

FIGURE 5. CACTUS GEOMETRY FOR UNH TURBINE.

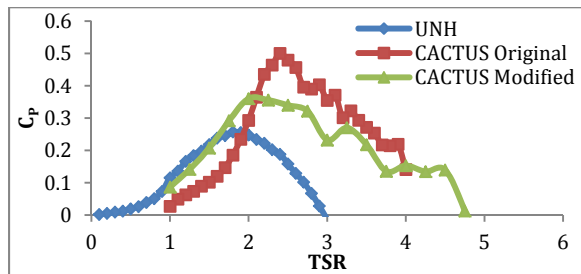

FIGURE 6. COMPARISON OF POWER COEFFICIENT BETWEEN UNH EXPERIMENT AND CACTUS SIMULATION.

USNA RM1

A 1:25 scale version of the DOE two-bladed axial flow RM1 turbine was tested at the United States Naval Academy (USNA)[7]. The scaled rotor has a diameter of 0.8m. A schematic of the test setup is shown in Figure 7. A simplified CACTUS model was created, since the specific blade geometry could not easily be accurately represented. The blade transitions from NACA 63-618 foil sections to thicker foils, to elliptical sections of different aspect ratios, and finally to circular sections. Elliptical sections are generally very difficult to model and little empirical data for elliptical sections exists. Efforts to obtain 2D empirical data would be of little use since transition regions at the root of rotating blades

are associated with 3D effects that would not be captured.

The CACTUS results are compared to the experimental data in Figure 8. Two different case studies were simulated with CACTUS. The first case study used the NACA 63-618 foils throughout the entire span of the blade, completely ignoring the transition region. This model, denoted 'CACTUS-1Foil' in Figure 8, over predicts the power coefficient as expected. The second case study, denoted 'CACTUS-1F+Cyl', simulates half of the transition region as a circular cylinder, and under predicts the power coefficient. The two models predicted simulations bound the experimental measurements.

Transition regions at the root of blades suffer from 3D effects not easily captured by CACTUS. Rotational augmentation is the occurrence of stall at higher angles of attacks and lift coefficients near the root of a rotating blade than for a two dimensional airfoil test[8]. One way this has been addressed in the past is by using the NREL methods in the AirfoilPrep routine to create different airfoil tables for each blade section according to their radial location, which somewhat account for the rotational stall delay effect. This is undesirable because it is burdensome and might not be accurate. Perhaps a better way to handle this, without having to apply individual corrections to each airfoil table used, would be to implement an integral boundary layer (IBL) calculation into CACTUS, which captures the 3D rotational effects. Some thought is needed to determine how to best implement this in the context of a blade element method, which uses empirical airfoil tables rather than calculating the chord-wise velocity and load distribution on the blade section.

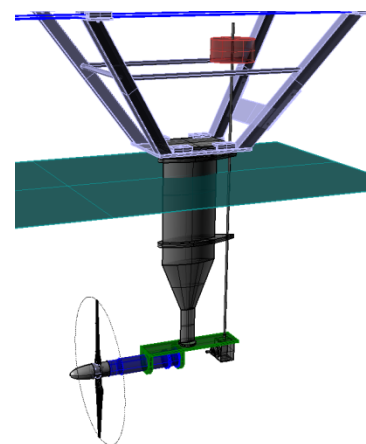

FIGURE 7. TEST SET-UP FOR THE SCALED RM1 TESTED AT USNA.

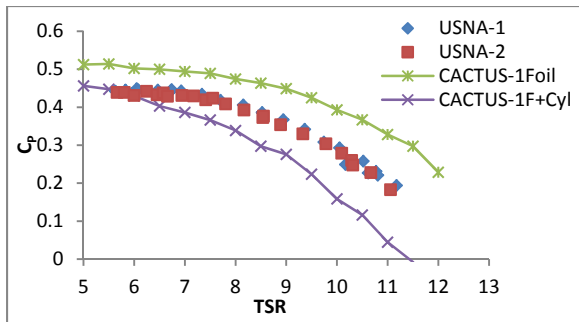

FIGURE 8. COMPARISON OF POWER COEFFICIENT BETWEEN USNA EXPERIMENT AND CACTUS SIMULATIONS.

CONCLUSIONS AND FUTURE WORK

CACTUS model performance was evaluated with measurements collected in three different experiments. The results show that CACTUS can be applied for axial flow hydrokinetic turbines, but that there may be limitations for hydrokinetic crossflow turbines with high chord-to-radius ratios. Problems predicting performance for circular and elliptical blade geometries and high chord-to-radius rotors requires further investigation. We discussed possible solutions to both of these problems in this paper.

Our validation efforts will continue as more MHK experimental data becomes available, including performance measurements to be collected at St. Anthony Falls Laboratory in 2014 for a dual rotor axial flow turbine and a dual rotor cross flow turbine. Several other scaled model turbine tests are underway or planned for the upcoming year, which will provide excellent opportunities to extend model validation tests to evaluate model performance.

ACKNOWLEDGMENTS

This work was funded by the Department of Energy's Wind and Water Power Technologies Office. Sandia National Laboratories is a multi-program laboratory managed and operated by Sandia Corporation, a wholly owned subsidiary of Lockheed Martin Corporation, for the U.S. Department of Energy's National Nuclear Security Administration under contract DE-AC04-94AL85000.

The authors wish to thank David Maniaci for reviewing this paper and for his input on model results discussions.

REFERENCES

[1] Barone M. F., and Murray J., 2011, "The Development of Cactus: A Wind and Marine Turbine Performance Simulation Code.," Proceedings of the 49th AIAA Aerospace Sciences Meeting including the New Horizons

Forum and Aerospace Exposition, Sandia National Laboratories, Orlando, Florida.

[2] Neary V. S., Fontaine A. A., Bachant P., Gunawan B., Wosnik M., Michelen C., Meyer R. J., and Straka W. A., 2013, "US Department of Energy (DOE) National Lab Activities in Marine Hydrokinetics: Scaled Model Testing of DOE Reference Turbines," Proceedings of the 10th European Wave and Tidal Energy Conference Series, Aalborg, Denmark.

[3] Johnson E., Barone M., Shiu H., van Dam C. P., Phillips R., Straka W., Fontaine A., and Jonson M., 2012, "A Design of a Hydrofoil Family for Current-Driven Marine-Hydrokinetic Turbines.," Proceedings of the 20th International Conference on Nuclear Engineering and ASME 2012 Power Conference, Anaheim, CA, USA.

[4] Johnson E., Fontaine A. A., Jonson M. L., Meyer R. S., Straka W. A., Young S., van Dam C. P., Shiu H., and Barone M., 2013, "A 1: 8.7 Scale Water Tunnel Test of an Axial Flow Water Turbine," Proceedings of the 1st Marine Energy Technology Symposium, METS13, Washington Dc.

[5] Tangler, James, Kocurek, J. David, 2005, "Wind turbine post-stall airfoil performance characteristics guidelines for blade-element momentum methods." 43rd AIAA Aerospace Sciences Meeting and Exhibit. Reno, Nevada.

[6] Bachant P., and Wosnik M., 2013, "Performance and Near-Wake Measurements for a Vertical Axis Turbine at Moderate Reynolds Number," Proceedings of the ASME 2013 Fluids Engineering Summer Meeting, Incline Village, Nevada, USA.

[7] Luksa Luznik, Max Van Benthem, Karen A. Flack, and Ethan E. Lust, 2013, "Near Wake Characteristics of a Model Horizontal Axis Marine Current Turbine under Steady and Unsteady Inflow Conditions," OCEANS'13 Conference Proceedings.

[8] Schreck S., and Robinson M., 2002, "Dynamic Stall and Rotational Augmentation in Recent Wind Turbine Aerodynamics Experiments (Invited)," American Institute of Aeronautics and Astronautics.